



High-Profile Wrap-N-Weigh Shown



Low-Profile Wrap-N-Weigh Shown

## FEATURES AND BENEFITS

### Machine Features

- Heavy-duty, welded-steel construction (no plastic panels) designed for long life
- Variable turntable speed using 1/2 hp, 90 Vdc motor with ANSI 50 chain drive system
- Up to 12 RPM rotating table can deliver 25–40 loads per hour
- Long range photo eye for automatic load height sensing
- Adjustable top and bottom illuminated LED wrap counters
- Cycle pause feature
- Top film overwrap control feature (TOC)
- Electronic film tension adjustment control on control panel
- Independent up and down film carriage controls with jog up/down switch
- Manual jog control for turntable
- Two available wrap patterns
- Dual chain film carriage lift
- Eco-friendly, durable powder coating

### Controls Hardware

- Allen-Bradley® power, control, and safety components
- Allen-Bradley® MicroLogix™ PLC
- UL/CSA approved components

## OPTIONS

- Access ramps to assist loading of pallet
- Automatic film tear device (AFTD) tears film at the end of the wrapping cycle
- Extended film towers for wrapping tall loads exceeding standard machine capability
- Cold and freezer packages available
- Adjustable manual roping guide
- Pneumatic roping device for extra load support
- 30" film delivery system
- Other NEMA rated control enclosures available
- Top platen device to stabilize tall or light unstable loads during rotation
- 6,000 lb. and large diameter turntables available
- Integrated scale and printer available



Note: Final Layout May Vary

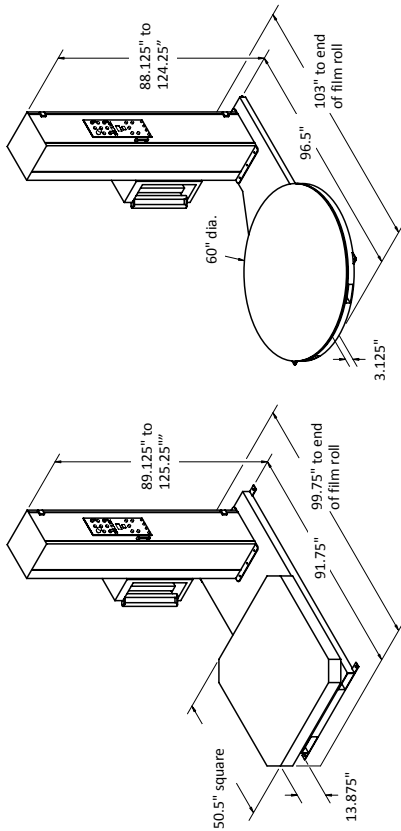

Specification	Measurement
<b>Turntable size – low-profile</b>	60" diameter (standard) 72" diameter (optional) (Larger sizes available)
<b>Turntable size – high-profile</b>	50" square (standard) 50" x 90" rectangular (option)
<b>Max. load diagonal clearance</b>	85" (standard turntable) 102" (optional turntable)
<b>Max. load weight</b>	4,000 lb. (standard) 6,000 lb. (option)
<b>Turntable rotation speed</b>	Up to 12 RPM
<b>Variable carriage speed</b>	Up to 21 FPM
<b>Loads wrapped per Hour</b>	25 to 40
<b>Max load height – low-profile:</b>	
- Standard power	83" max load height
- Optional extensions available (12, 24, and 36")	95", 107", and 119" options
<b>Max load height – high-profile:</b>	
- Standard tower	74" max load height
- Optional extensions available (12", 24", and 36")	86", 98", and 110" option
<b>Electrical power requirements</b>	120 Vac, 1 Ph, 60 Hz, 10 A, 1.2 kW
<b>Standard shipping weight</b>	Low-profile 1,350 lb. High-profile 1,260 lb.



Optional Ramps Available



Optional Automatic Roping Device



Optional 90" Table

**Complete Aftermarket Service & Support for Your Packaging Equipment**

**SUPPORTPRO™**

A DURAVANT SERVICE

Call **844.777.8776** for your regional tech

**24/7 Help Available**



THE DURAVANT FAMILY OF COMPANIES

ARPAC | FISCHBEIN INTERNATIONAL | FMH CONVEYORS | HAMER-FISCHBEIN | KEY TECHNOLOGY | MARLEN INTERNATIONAL | MESPACK | OHLSON | QC INDUSTRIES

[www.duravant.com](http://www.duravant.com)